



SF-B115 Series

ANSI
ASME
B18.3

STAINLESS STEEL 316

Rockwell C25~



RoHS Directive Compliance

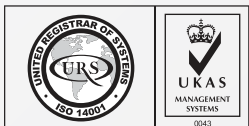

SOCKET CAP SCREW INCH (UNF THREAD)

STAINLESS STEEL 316 (C25~ RATED)

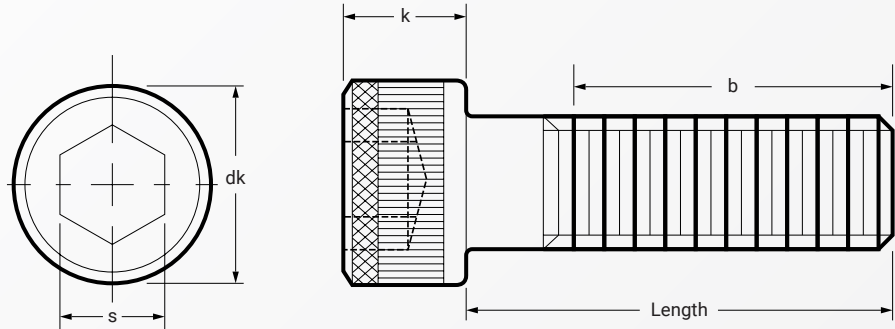

Dimension	threads per inch UNRF	dk	k	s	b	Length
#0	80	.096	.060	.050	.500	from 1/16"
#1	72	.118	.073	.062	.625	from 1/8"
#2	64	.140	.086	.078	.625	from 1/16"
#3	56	.161	.099	.078	.625	from 1/8"
#4	48	.183	.112	.094	.750	from 3/32"
#5	44	.205	.125	.094	.750	from 3/32"
#6	40	.226	.138	.109	.750	from 3/32"
#8	36	.270	.164	.141	.875	from 3/32"
#10	32	.312	.190	.156	.875	from 5/32"
1/4	28	.375	.250	.188	1.000	from 1/4"
5/16	24	.469	.312	.250	1.125	from 1/4"
3/8	24	.562	.375	.312	1.250	from 3/8"
7/16	20	.656	.437	.375	1.375	from 3/8"
1/2	20	.750	.500	.375	1.500	from 1/2"
9/16	18	.843	.562	.438	1.625	from 1"
5/8	18	.938	.625	.500	1.750	from 1/2"
3/4	16	1.125	.750	.625	2.000	from 3/4"

Above datas are for reference only

* denotes not standardized, reference values

Note:

B115 denotes Stainless Steel 316 plain with Rockwell C25~ hardness in UNF series

Part number built example:

e.g. (1) Diameter #10-32 X 1-3/4" in stainless steel 316 >> B115 #10X1-3/4

e.g. (2) Diameter 3/4-16 X 3-1/2" in stainless steel 316 >> B115 3/4X3-1/2



sales@synergixfast.com



www.synergixfast.com



Phone: +65 6 316 2630 | Fax: +65 6 316 2730