



SF-D200 Series

IFI 111
ASTM F593

STAINLESS STEEL 18-8

PLAIN

Other Finish Options:
BLACK OXIDE



RoHS Directive Compliance

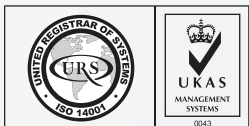
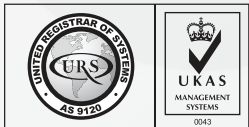

HEXAGON HEAD FLANGE SCREW INCH (UNC THREAD) STAINLESS STEEL 18-8

PLAIN | BLACK OXIDE*

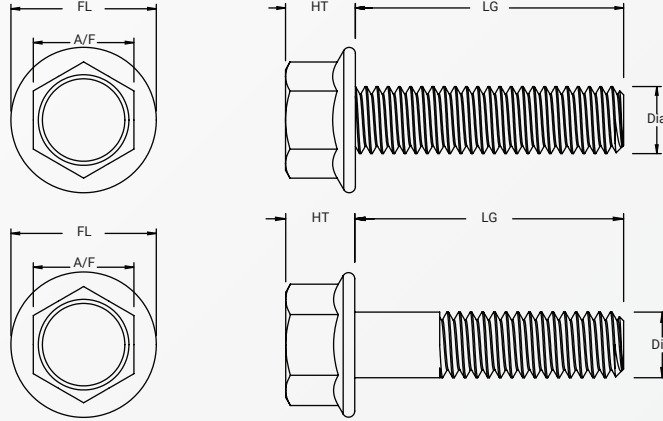

Dimension (UNC)	Head Width (A/F)	Head Height (HT)	Flange Dia. (FL)	Length (LG)	Thread
FULL THREAD OPTION					
1/4"-20	3/8"	9/32"	9/16"	from 1/2"	Full
5/16"-18	1/2"	21/64"	11/16"	from 3/4"	Full
3/8"-16	9/16"	25/64"	13/16"	from 3/4"	Full
1/2"-13	3/4"	33/64"	1 5/64"	from 1.0"	Full
PARTIAL THREAD OPTION					
1/4"-20	3/8"	9/32"	9/16"	from 1-1/2"	min 3/4"
5/16"-18	1/2"	21/64"	11/16"	from 1-1/2"	min 7/8"
3/8"-16	9/16"	25/64"	13/16"	from 1-3/4"	min 1.0"
1/2"-13	3/4"	33/64"	1 5/64"	from 2.0"	min 1-1/4"

Above datas are for reference only

Note:

D200 denotes unc hex flange screw in stainless steel 18-8

Full & partial thread as above both tables described

*For optional finish, add "-BO" for black oxide on part number

Part number built example:

e.g. (1) Diameter 1/2-13 X 1" in stainless steel 18-8

» SF-D200 1/2X1

e.g. (2) Diameter 1/2-13 X 1" in stainless steel 18-8 black oxide

» SF-D200 1/2X1-BO



sales@synergixfast.com



www.synergixfast.com



Phone: +65 6 316 2630 | Fax: +65 6 316 2730

page 1/2