



SF-F022 Series

ASME B18.2.2
SAE J995~

CARBON STEEL GRADE 8

ZINC YELLOW

Other Finish Options:
BLACK OXIDE
ZINC FLAKES



RoHS Directive Compliance

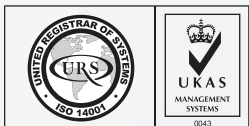
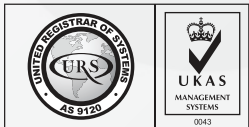

HEXAGON NUT INCH (UNF THREAD) CARBON STEEL GRADE 8

ZINC YELLOW | BLACK OXIDE* | ZINC FLAKES*

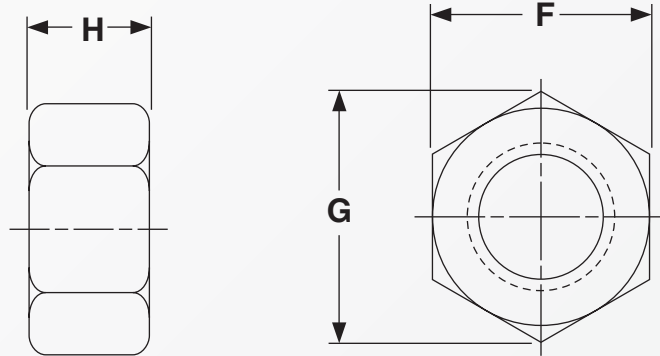

Dimension	Threads per inch UNRF	F		G	H	
		Width Across Flats		Width Across Corners	Thickness of Hex Nuts	
		Basic	Max	Max	Basic	Max
1/4	28	7/16	0.438	0.505	7/32	0.226
5/16	24	1/2	0.500	0.577	17/64	0.273
3/8	24	9/16	0.562	0.650	21/64	0.337
7/16	20	11/16	0.688	0.794	3/8	0.385
1/2	18	3/4	0.750	0.866	7/16	0.448
9/16	18	7/8	0.875	1.010	31/64	0.496
5/8	16	15/16	0.938	1.083	35/64	0.559
3/4	14	1-1/8	1.125	1.299	41/64	0.665
7/8	12	1-5/16	1.312	1.516	3/4	0.776
1	14*	1-1/2	1.500	1.732	55/64	0.887
1 1/8	12	1-11/16	1.688	1.949	31/32	0.999
1 1/4	12	1-7/8	1.875	2.165	1 1/16	1.094
1 3/8	12	2-1/16	2.062	2.382	1 11/64	1.206
1 1/2	12	2-1/4	2.250	2.598	1 9/32	1.317

Above datas are for reference only

Note:

F020 denotes unf hex nuts in steel zinc yellow grade 8 rated

Zinc flakes plating also known as zinc aluminium, are more corrosion resistance in wet environment

*For optional finish, add "-BO" for black oxide | "-ZFL" for zinc flakes on part number

Part number built example:

e.g. (1) Diameter 3/4-16 in steel gr8 zinc yellow

» SF-F022 3/4

e.g. (2) Diameter 3/4-16 in steel gr8 black oxide

» SF-F022 3/4-BO

e.g. (3) Diameter 3/4-16 in steel gr8 zinc flakes

» SF-F022 3/4-ZFL



sales@synergixfast.com



www.synergixfast.com



Phone: +65 6 316 2630 | Fax: +65 6 316 2730