

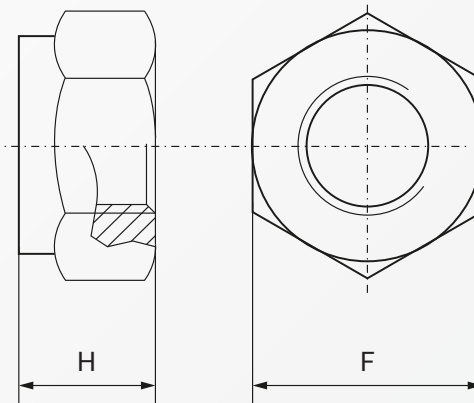

# HEXAGON LOCK NUT WITH NYLON INSERT INCH (UNC & UNF THREAD) THIN TYPE

CARBON STEEL | ZINC PLATE



SF-F080 Series (UNC)  
SF-F082 Series (UNF)

CARBON STEEL

ZINC PLATE

Dimension	Width (F)	Height (H)
#2-56	1/4"	7/64"
#4-40	1/4"	7/64"
#5-40	1/4"	7/64"
#6-32	5/16"	1/8"
#8-32	11/32"	11/64"
#10-24	3/8"	11/64"
#10-32	3/8"	11/64"
#12-24	7/16"	13/64"
1/4"-20	7/16"	13/64"
1/4"-28	7/16"	13/64"
5/16"-18	1/2"	1/4"
5/16"-24	1/2"	1/4"
3/8"-16	9/16"	17/64"
3/8"-24	9/16"	17/64"
7/16"-14	5/8"	5/16"
7/16"-20	5/8"	5/16"
1/2"-13	3/4"	5/16"

Dimension	Width (F)	Height (H)
1/2"-20	3/4"	5/16"
9/16"-12	7/8"	23/64"
9/16"-18	7/8"	23/64"
5/8"-11	15/16"	25/64"
5/8"-18	15/16"	25/64"
3/4"-10	1 1/16"	13/32"
3/4"-16	1 1/16"	13/32"
7/8"-9	1 1/4"	15/32"
7/8"-14	1 1/4"	15/32"
1"-8	1 7/16"	35/64"
1"-14	1 7/16"	35/64"
1 1/8"-7	1 5/8"	41/64"
1 1/4"-7	1 13/16"	3/4"
1 1/4"-12	1 13/16"	3/4"
1 3/8"-6	2"	51/64"
1 1/2"-6	2 3/16"	51/64"



RoHS Directive Compliance

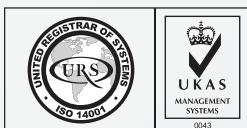

Above datas are for reference only

Note:

F080 denotes unc hex lock nuts thin height in steel zinc plate

F082 denotes unf hex lock nuts thin height in steel zinc plate

For use at temperature max. 100 degree (220 Fahrenheit)

Size in red color are denoted as unf thread

Part number built example:

e.g. (1) Diameter 1/4-20 in steel zinc plate

» SF-F080 1/4

e.g. (2) Diameter 1/4-28 in steel zinc plate

» SF-F082 1/4



sales@synergixfast.com



www.synergixfast.com



Phone: +65 6 316 2630 | Fax: +65 6 316 2730