



SF-F084 Series (UNC)
SF-F085 Series (UNF)

CARBON STEEL GRADE 5

ZINC PLATE



RoHS Directive Compliance

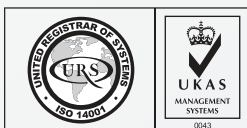

HEXAGON LOCK NUT WITH NYLON INSERT INCH (UNC & UNF THREAD) THIN TYPE

CARBON STEEL GRADE 5 | ZINC PLATE

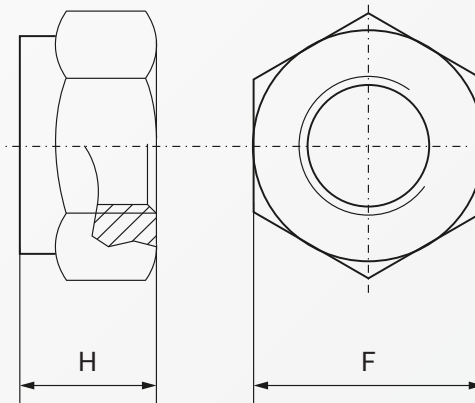

Dimension	Width (F)	Height (H)
5/8"-11	15/16"	25/64"
5/8"-18	15/16"	25/64"
3/4"-10	1 1/16"	13/32"
3/4"-16	1 1/16"	13/32"
7/8"-14	1 1/4"	15/32"
1"-8	1 7/16"	35/64"
1"-14	1 7/16"	35/64"
1 1/8"-7	1 5/8"	41/64"
1 1/4"-7	1 13/16"	3/4"
1 1/4"-12	1 7/8"	3/4"
1 1/2"-6	2 3/16"	51/64"

Above datas are for reference only

Note:

F084 denotes unc hex lock nuts thin height in steel grade 5 zinc plate

F085 denotes unf hex lock nuts thin height in steel grade 5 zinc plate

For use at temperature max. 100 degree (220 Fahrenheit)

Size in red color are denoted as unf thread

Part number built example:

e.g. (1) Diameter 5/8-11 in steel g5 zinc plate

» SF-F084 5/8

e.g. (2) Diameter 5/8-18 in steel g5 zinc plate

» SF-F085 5/8



sales@synergixfast.com



www.synergixfast.com



Phone: +65 6 316 2630 | Fax: +65 6 316 2730