



SF-E035 SERIES

ISO 4032
DIN 934

STEEL

CLASS 12

BLACK



RoHS Directive Compliance

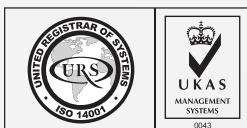

HEXAGON NUT

STEEL CLASS 12 | BLACK

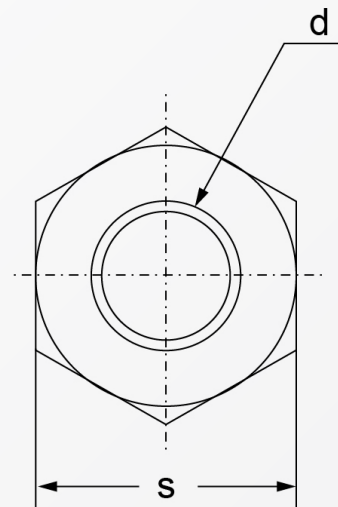
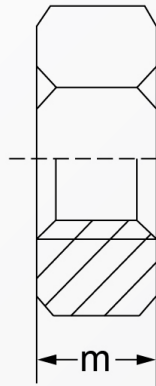

Dimension	m _{ISO/DIN}	s _{ISO/DIN}
M 1	0.8	2.5
M 1.2	1	3
M 1.4	1.2	3
M 1.6	1.3	3.2
M 1.7*	1.4	3.5
M 2	1.6	4
M 2.3*	1.8	4.5
M 2.5	2	5
M 2.6*	2	5
M 3	2.4	5.5
M 3.5	2.8	6
M 4	3.2	7
M 5	4.7/4	8
M 6	5.2/5	10
M 7	5.5	11
M 8	6.8/6.5	13
M 10	8.4/8	16/17
M 12	10.8/10	18/19
M 14	12.8/11	21/22
M 16	14.8/13	24

Dimension	m _{ISO/DIN}	s _{ISO/DIN}
M 18	15.8/15	27
M 20	18/16	30
M 22	19.4/18	34/32
M 24	21.5/19	36
M 26*	22	41
M 27	23.8/22	41
M 28 **	22	41
M 30	25.6/24	46
M 32**	26	50
M 33	28.7/26	50
M 35**	29	55
M 36	31/29	55
M 38**	31	60
M 39	33.4/31	60
M 40**	31	60
M 42	34	65
M 45	36	70
M 48	38	75
M 50	38	75
M 52	42	80

Above datas are for reference only

* denotes acc. to DIN 934

** denotes not standardized, reference values

Class 12 material, starts from M6 diameter

Note:

E035 denotes steel class 12 black

Part number built example:

e.g. (1) Diameter M16 in steel class 12 material

»SF-E035 M16



sales@synergixfast.com



www.synergixfast.com



Phone: +65 6 316 2630 | Fax: +65 6 316 2730