



## SF-E076 SERIES

DIN 986

STEEL

CLASS 6

ZINC PLATE



RoHS Directive Compliance

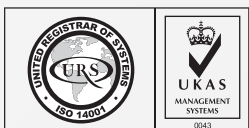

# DOMED LOCK NUT (WITH NYLON INSERT)

STEEL CLASS 6 | ZINC

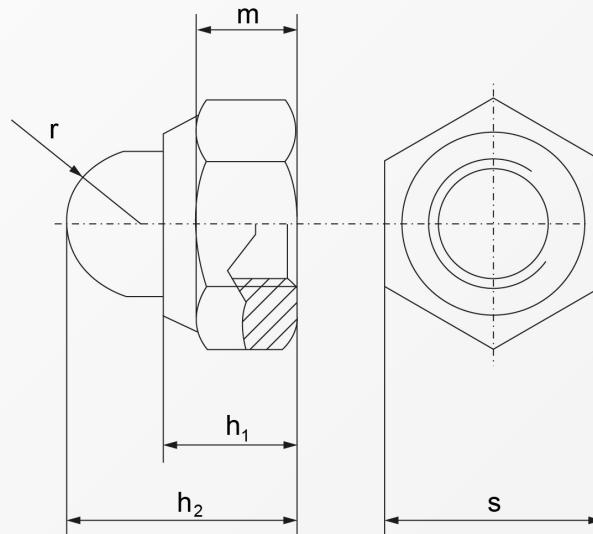

Dimension	$h_1$	$h_2$	$m_{min.}$	$r$	$s$
M 4	5.6	9.6	2.9	2.5	7
M 5	6	10.5	4.4	3	8
M 6	7.5	12	4.9	3.5	10
M 8	8.9	14	6.44	4.6	13
M 10	10.5	18.1	8.04	5.8	17
M 12	13.5	22.5	10.37	6.8	19
M 16	16.5	27.5	14.1	8.8	24

Above datas are for reference only  
For use under temperature -50 to +120 degree

Note:  
E076 denotes steel class 6 zinc

Part number built example:

e.g. (1) Diameter M8 in steel class 6 material   » SF-E076 M8



sales@synergixfast.com



www.synergixfast.com



Phone: +65 6 316 2630 | Fax: +65 6 316 2730