



SF-G001 SERIES

JIS B 1111

STEEL

4.8

ZINC PLATE



RoHS Directive Compliance

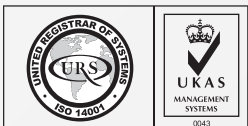
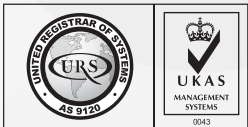

JIS PAN HEAD SCREW PHILIPS CROSS RECESS

STEEL GRADE 4.8 ZINC

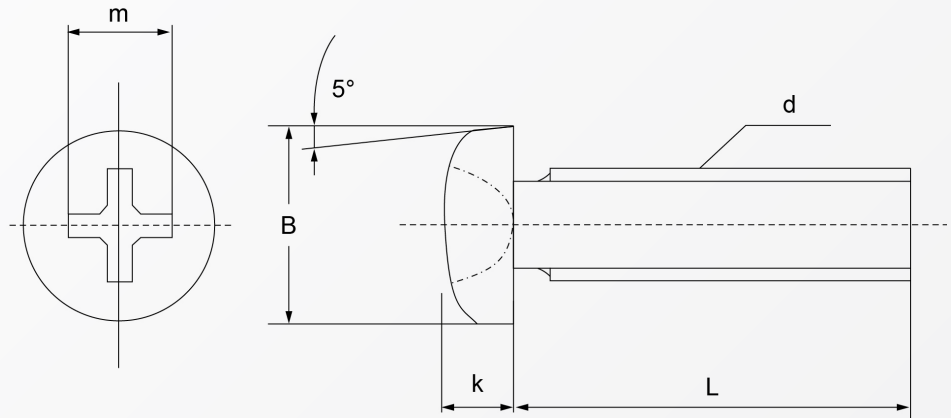

Screw nominal ($\varnothing d$)	Pitch (P)	Number of crosshole	Reference dimension		Length
			B	k	
M2	0.4	1	3.5	1.3	from 3mm
M2.6	0.45		4.5	1.7	from 4mm
M3	0.5	2	5.5	2	from 4mm
M4	0.7		7	2.6	from 5mm
M5	0.8		9	3.3	from 6mm
M6	1	3	10.5	3.9	from 8mm
M8	1.25		14	5.2	from 10mm
M10	1.5	4	17.5	6.5	from 16mm

Above datas are for reference only
m dimension = ref.

Note:
G001 denotes steel 4.8 zinc

Part number built example :

e.g. (1) Diameter 3X6 thread in steel 4.8 zinc »SF-G001 3X6



sales@synergixfast.com



www.synergixfast.com



Phone: +65 6 316 2630 | Fax: +65 6 316 2730