



SF-I016 SERIES

DIN 463

STEEL

ZINC



RoHS Directive Compliance

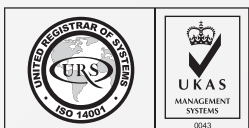

TAP WASHERS (WITH O2 TAPS)

STEEL ZINC

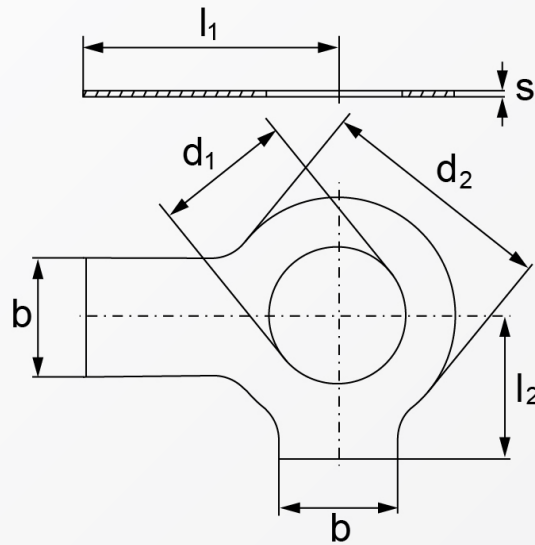

Dimensions	d_2	b	l_1	l_2	s	for thread \emptyset
3.2	7	4	13	5	0.38	3
4.3	9	5	14	6.5	0.38	4
5.3	10	6	16	8	0.5	5
6.4	12.5	7	18	9	0.5	6
8.4	17	8	20	11	0.75	8
10.5	21	10	22	13	0.75	10
13	24	12	28	15	1	12
15	28	12	28	16	1	14
17	30	15	32	18	1	16
19	34	18	36	20	1	18
21	37	18	36	21	1	20
23	39	20	42	23	1	22
25	44	20	42	25	1	24
28	50	23	48	29	1.6	27
31	56	26	52	32	1.6	30
34	60	28	56	34	1.6	33
37	66	30	60	38	1.6	36
40	72	32	64	41	1.6	39
43	78	35	70	44	1.6	42
50	92	40	80	50	1.6	48
54	98	44	85	53	1.6	52

Above datas are for reference only
 d_1 = nominal size

Note:
 I016 denotes tab washer in steel zinc

Part number built example:
 e.g. (1) Diameter 10.5 in steel zinc >>SF-I016 10.5



sales@synergixfast.com

www.synergixfast.com

Phone: +65 6 316 2630 | Fax: +65 6 316 2730