



SF-I350 SERIES
SF-I360 SERIES

DIN 7603

COPPER
ALUMINIUM



RoHS Directive Compliance

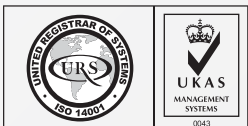
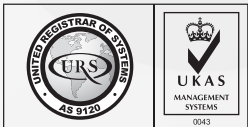

FLAT SEALING RING

COPPER | ALUMINIUM

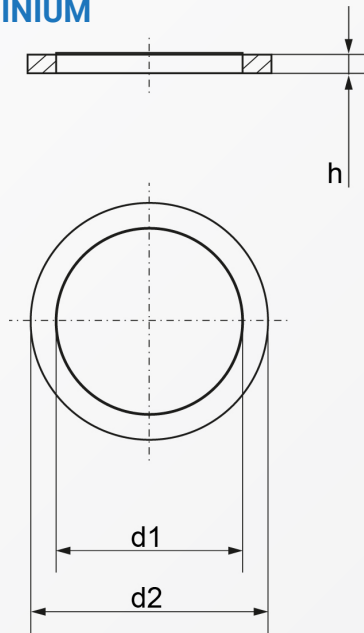

Dimension	d ₁	d ₂	h
4x8	4.2	7.9	1
5x7.5	5.2	7.4	1
5x9*	5.2	8.9	1
6x10*	6.2	9.9	1
6.5x9.5	6.7	9.4	1
6.5x11*	6.7	10.9	1
8x11.5	8.2	11.4	1
8x12*	8.2	11.9	1/1.5
8x14	8.2	13.9	1
10x13.5	10.2	13.4	1
10x14*	10.2	13.9	1/1.5
10x15*	10.2	14.9	1
10x16	10.2	15.9	1
10x18	10.2	17.9	1.5
12x15.5	12.2	15.4	1.5
12x16	12.2	15.9	1.5
12x17*	12.2	16.9	1.5
12x18*	12.2	17.9	1.5
13x18*	13.2	17.9	1.5
14x18	14.2	17.9	1.5
14x20	14.2	19.9	1.5
15x19	15.2	18.9	1.5
16x20	16.2	19.9	1.5
16x22*	16.2	21.9	1.5

Above datas are for reference only
 material : Al operating temperature : max. 200 °C
 material : Cu operating temperature : max. 300 °C
 * not standardized, reference values

Part number built example:

- e.g. (1) 17X21X1.5 in copper material >> SF-I350 17X21X1.5
- e.g. (2) 23X28X2 in aluminium material >> SF-I360 23X28X2



sales@synergixfast.com



www.synergixfast.com



Phone: +65 6 316 2630 | Fax: +65 6 316 2730