



SF-K040 SERIES  
SF-K120 SERIES

DIN 471

STEEL BLACK

STAINLESS STEEL  
1.4122\*\*



RoHS Directive Compliance

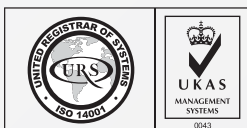

## RETAINING RING FOR SHAFTS (NORMAL TYPE)

STEEL BLACK | STAINLESS STEEL 1.4122\*\*

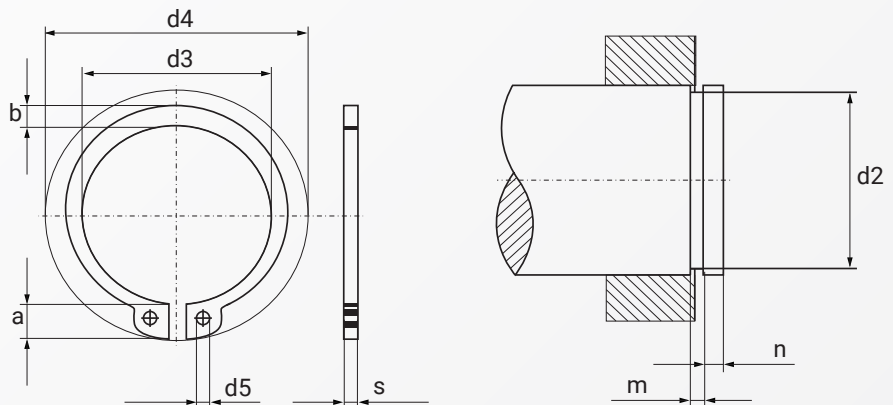

Dimensions	s	d <sub>3</sub>	a	b	d <sub>5</sub>	d <sub>2</sub>	m	n	d <sub>4</sub>
3	0.4	2.7	1.9	0.8	1	2.8	0.5	0.3	7
4	0.4	3.7	2.2	0.9	1	3.8	0.5	0.3	8.6
5	0.6	4.7	2.5	1.1	1	4.8	0.7	0.3	10.3
6	0.7	5.6	2.7	1.3	1.2	5.7	0.8	0.5	11.7
7	0.8	6.5	3.1	1.4	1.2	6.7	0.9	0.5	13.5
8	0.8	7.4	3.2	1.5	1.2	7.6	0.9	0.6	14.7
9	1	8.4	3.3	1.7	1.2	8.6	1.1	0.6	16
10	1	9.3	3.3	1.8	1.5	9.6	1.1	0.6	17
11	1	10.2	3.3	1.8	1.5	10.5	1.1	0.8	18
12	1	11	3.3	1.8	1.7	11.5	1.1	0.8	19
13	1	11.9	3.4	2	1.7	12.4	1.1	0.9	20.2
14	1	12.9	3.5	2.1	1.7	13.4	1.1	0.9	21.4
15	1	13.8	3.6	2.2	1.7	14.3	1.1	1.1	22.6
16	1	14.7	3.7	2.2	1.7	15.2	1.1	1.2	23.8
17	1	15.7	3.8	2.3	1.7	16.2	1.1	1.2	25
18	1.2	16.5	3.9	2.4	2	17	1.3	1.5	26.2
19	1.2	17.5	3.9	2.5	2	18	1.3	1.5	27.2
20	1.2	18.5	4	2.6	2	19	1.3	1.5	28.4
21	1.2	19.5	4.1	2.7	2	20	1.3	1.5	29.6
22	1.2	20.5	4.2	2.8	2	21	1.3	1.5	30.8
23*	1.2	21.5	4.3	2.9	2	22	1.3	1.5	-
24	1.2	22.2	4.4	3	2	22.9	1.3	1.7	33.2
25	1.2	23.2	4.4	3	2	23.9	1.3	1.7	34.2
26	1.2	24.2	4.5	3.1	2	24.9	1.3	1.7	35.5

Above datas are for reference only  
\*dimensions not listed in standard  
\*\*stainless material up to diameter 100

Part number built example:

e.g. (1) Select Diameter 20 in steel material      »SF-K040 20.0  
e.g. (2) Select Diameter 55 in stainless material    »SF-K120 55.0



sales@synergixfast.com



www.synergixfast.com



Phone: +65 6 316 2630 | Fax: +65 6 316 2730



SF-K040 SERIES  
SF-K120 SERIES

DIN 471

STEEL BLACK

STAINLESS STEEL  
1.4122\*\*



RoHS Directive Compliance

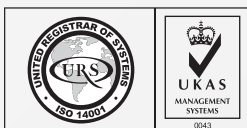

## RETAINING RING FOR SHAFTS (NORMAL TYPE)

STEEL BLACK | STAINLESS STEEL 1.4122\*\*

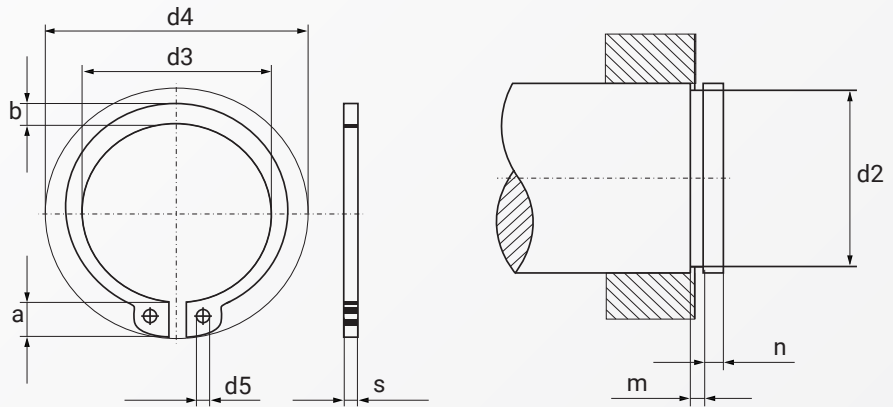

Dimensions	s	d <sub>3</sub>	a	b	d <sub>5</sub>	d <sub>2</sub>	m	n	d <sub>4</sub>
27*	1.2	24.9	4.6	3.1	2	25.6	1.3	2.1	-
28	1.5	25.9	4.7	3.2	2	26.6	1.6	2.1	37.9
29	1.5	26.9	4.8	3.4	2	27.6	1.6	2.1	39.1
30	1.5	27.9	5	3.5	2	28.6	1.6	2.1	40.5
31*	1.5	28.6	5.1	3.5	2.5	29.3	1.6	2.6	-
32	1.5	29.6	5.2	3.6	2.5	30.3	1.6	2.6	43
33*	1.5	30.5	5.2	3.7	2.5	31.3	1.6	2.6	-
34	1.5	31.5	5.4	3.8	2.5	32.3	1.6	2.6	45.4
35	1.5	32.2	5.6	3.9	2.5	33	1.6	3	46.8
36	1.75	33.2	5.6	4	2.5	34	1.85	3	47.8
37*	1.75	34.2	5.7	4.1	2.5	35	1.85	3	-
38	1.75	35.2	5.8	4.2	2.5	36	1.85	3	50.2
39*	1.75	36	5.9	4.3	2.5	37	1.85	3	-
40	1.75	36.5	6	4.4	2.5	37.5	1.85	3.8	52.6
41*	1.75	37.5	6.2	4.5	2.5	38.5	1.85	3.8	-
42	1.75	38.5	6.5	4.5	2.5	39.5	1.85	3.8	55.7
44*	1.75	40.5	6.6	4.6	2.5	41.5	1.85	3.8	-
45	1.75	41.5	6.7	4.7	2.5	42.5	1.85	3.8	59.1
46*	1.75	42.5	6.7	4.8	2.5	43.5	1.85	3.8	-
47*	1.75	43.5	6.8	4.9	2.5	44.5	1.85	3.8	-
48	1.75	44.5	6.9	5	2.5	45.5	1.85	3.8	62.5
50	2	45.8	6.9	5.1	2.5	47	2.15	4.5	64.5
52	2	47.8	7	5.2	2.5	49	2.15	4.5	66.7
54*	2	49.8	7.1	5.3	2.5	51	2.15	4.5	-

Above datas are for reference only  
\*dimensions not listed in standard  
\*\*stainless material up to diameter 100

Part number built example:

e.g. (1) Select Diameter 20 in steel material      »SF-K040 20.0  
e.g. (2) Select Diameter 55 in stainless material    »SF-K120 55.0



sales@synergixfast.com



www.synergixfast.com



Phone: +65 6 316 2630 | Fax: +65 6 316 2730



SF-K040 SERIES  
SF-K120 SERIES

DIN 471

STEEL BLACK

STAINLESS STEEL  
1.4122\*\*



RoHS Directive Compliance

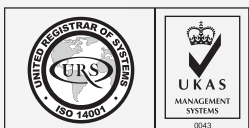

## RETAINING RING FOR SHAFTS (NORMAL TYPE)

STEEL BLACK | STAINLESS STEEL 1.4122\*\*

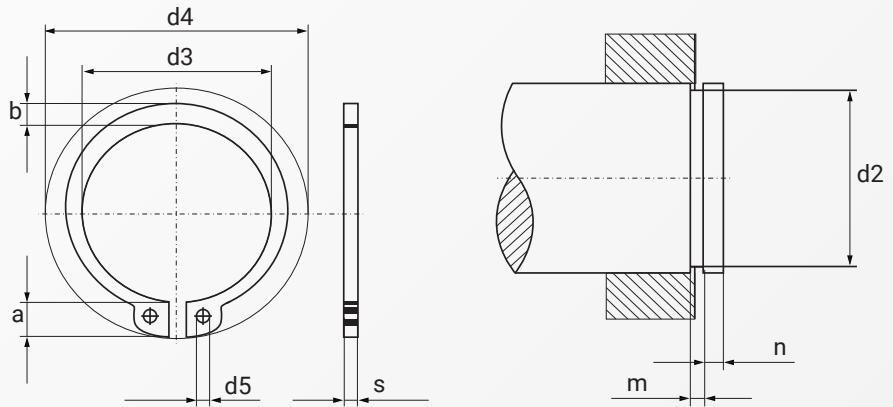

Dimensions	s	d <sub>3</sub>	a	b	d <sub>5</sub>	d <sub>2</sub>	m	n	d <sub>4</sub>
55	2	50.8	7.2	5.4	2.5	52	2.15	4.5	70.2
56	2	51.8	7.3	5.5	2.5	53	2.15	4.5	71.6
57*	2	52.8	7.3	5.5	2.5	54	2.15	4.5	-
58	2	53.8	7.3	5.6	2.5	55	2.15	4.5	73.6
60	2	55.8	7.4	5.8	2.5	57	2.15	4.5	75.6
62	2	57.8	7.5	6	2.5	59	2.15	4.5	77.8
63	2	58.8	7.6	6.2	2.5	60	2.15	4.5	79
65	2.5	60.8	7.8	6.3	3	62	2.65	4.5	81.4
67*	2.5	62.5	7.9	6.4	3	64	2.65	4.5	-
68	2.5	63.5	8	6.5	3	65	2.65	4.5	84.8
70	2.5	65.5	8.1	6.6	3	67	2.65	4.5	87
72	2.5	67.5	8.2	6.8	3	69	2.65	4.5	89.2
75	2.5	70.5	8.4	7	3	72	2.65	4.5	92.7
77*	2.5	72.5	8.5	7.2	3	74	2.65	4.5	-
78	2.5	73.5	8.6	7.3	3	75	2.65	4.5	96.1
80	2.5	74.5	8.6	7.4	3	76.5	2.65	5.3	98.1
82	2.5	76.5	8.7	7.6	3	78.5	2.65	5.3	100.3
85	3	79.5	8.7	7.8	3.5	81.5	3.15	5.3	103.3
87*	3	81.5	8.8	7.9	3.5	83.5	3.15	5.3	-
88	3	82.5	8.8	8	3.5	84.5	3.15	5.3	106.5
90	3	84.5	8.8	8.2	3.5	86.5	3.15	5.3	108.5
92*	3	86.5	9	8.4	3.5	88.5	3.15	5.3	-
97*	3	91.5	9.4	8.8	3.5	93.5	3.15	5.3	-
98*	3	91.5	9.4	8.8	3.5	94.5	3.15	5.3	-

Above datas are for reference only  
\*dimensions not listed in standard  
\*\*stainless material up to diameter 100

Part number built example:

e.g. (1) Select Diameter 20 in steel material      »SF-K040 20.0  
e.g. (2) Select Diameter 55 in stainless material    »SF-K120 55.0



sales@synergixfast.com

www.synergixfast.com

Phone: +65 6 316 2630 | Fax: +65 6 316 2730



SF-K040 SERIES  
SF-K120 SERIES

DIN 471

STEEL BLACK

STAINLESS STEEL  
1.4122\*\*



RoHS Directive Compliance

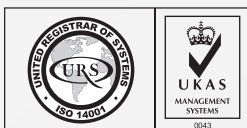

## RETAINING RING FOR SHAFTS (NORMAL TYPE)

STEEL BLACK | STAINLESS STEEL 1.4122\*\*

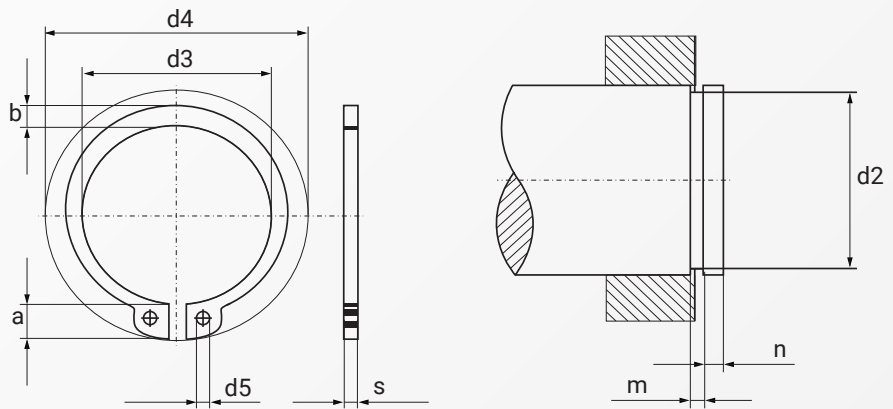

Dimensions	s	d <sub>3</sub>	a	b	d <sub>5</sub>	d <sub>2</sub>	m	n	d <sub>4</sub>
100	3	94.5	9.6	9	3.5	96.5	3.15	5.3	120.2
102*	4	95	9.7	9.2	3.5	98	4.15	6	-
105	4	98	9.9	9.3	3.5	101	4.15	6	125.8
107*	4	100	10	9.5	3.5	103	4.15	6	-
108*	4	100	10	9.5	3.5	104	4.15	6	-
110	4	103	10.1	9.6	3.5	106	4.15	6	131.2
112*	4	105	10.3	9.7	3.5	108	4.15	6	-
115	4	108	10.6	9.8	3.5	111	4.15	6	137.3
117*	4	110	10.8	10	3.5	113	4.15	6	-
118*	4	110	10.8	10	3.5	114	4.15	6	-
120	4	113	11	10.2	3.5	116	4.15	6	143.1
122*	4	115	11.2	10.3	4	118	4.15	6	-
125	4	118	11.4	10.4	4	121	4.15	6	149
127*	4	120	11.4	10.5	4	123	4.15	6	-
128*	4	120	11.4	10.5	4	124	4.15	6	-
130	4	123	11.6	10.7	4	126	4.15	6	154.4
132*	4	125	11.7	10.8	4	128	4.15	6	-
135	4	128	11.8	11	4	131	4.15	6	159.8
137*	4	130	11.9	11	4	133	4.15	6	-
138*	4	130	11.9	11	4	134	4.15	6	-
140	4	133	12	11.2	4	136	4.15	6	165.2
142*	4	135	12.1	11.3	4	138	4.15	6	-
145	4	138	12.2	11.5	4	141	4.15	6	170.6
147*	4	140	12.3	11.6	4	143	4.15	6	-

Above datas are for reference only  
\*dimensions not listed in standard  
\*\*stainless material up to diameter 100

Part number built example:

e.g. (1) Select Diameter 20 in steel material   » SF-K040 20.0  
e.g. (2) Select Diameter 55 in stainless material » SF-K120 55.0



sales@synergixfast.com

www.synergixfast.com

Phone: +65 6 316 2630 | Fax: +65 6 316 2730



SF-K040 SERIES  
SF-K120 SERIES

DIN 471

STEEL BLACK

STAINLESS STEEL  
1.4122\*\*



RoHS Directive Compliance

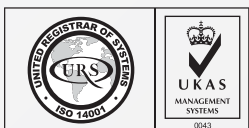

## RETAINING RING FOR SHAFTS (NORMAL TYPE)

STEEL BLACK | STAINLESS STEEL 1.4122\*\*

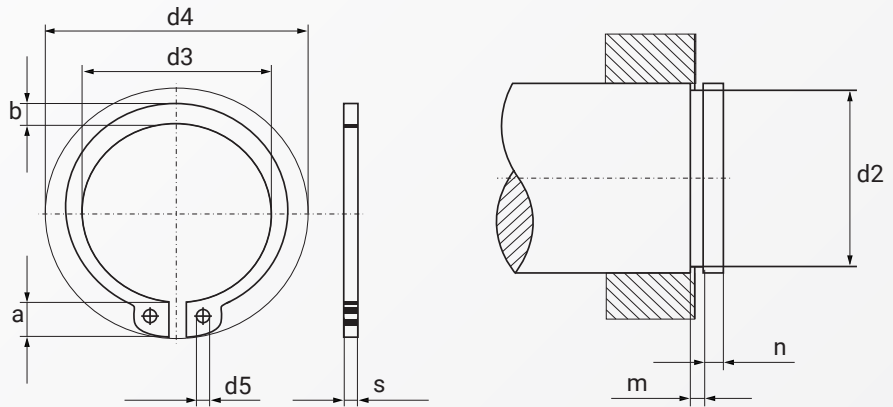

Dimensions	s	d <sub>3</sub>	a	b	d <sub>5</sub>	d <sub>2</sub>	m	n	d <sub>4</sub>
148*	4	140	12.3	11.6	4	144	4.15	6	-
150	4	142	13	11.8	4	145	4.15	7.5	177.3
155	4	146	13	12	4	150	4.15	7.5	182.3
160	4	151	13.3	12.2	4	155	4.15	7.5	188
165	4	155.5	13.5	12.5	4	160	4.15	7.5	193.4
168*	4	157.5	13.5	12.9	4	163	4.15	7.5	-
170	4	160.5	13.5	12.9	4	165	4.15	7.5	198.4
175	4	165.5	13.5	12.9	4	170	4.15	7.5	203.4
180	4	170.5	14.2	13.5	4	175	4.15	7.5	210
185	4	175.5	14.2	13.5	4	180	4.15	7.5	215
190	4	180.5	14.2	14	4	185	4.15	7.5	220
195	4	185.5	14.2	14	4	190	4.15	7.5	225
200	4	190.5	14.2	14	4	195	4.15	7.5	230
210	5	198	14.2	14	4	204	5.15	9	240
215*	5	203	14.2	14	4	209	5.15	9	-
220	5	208	14.2	14	4	214	5.15	9	250
230	5	218	14.2	14	4	224	5.15	9	260
240	5	228	14.2	14	4	234	5.15	9	270
250	5	238	14.2	14	4	244	5.15	9	280
255*	5	240	16.2	16	5	247	5.15	12	-
260	5	245	16.2	16	5	252	5.15	12	294
270	5	255	16.2	16	5	262	5.15	12	304
280	5	265	16.2	16	5	272	5.15	12	314
290	5	275	16.2	16	5	282	5.15	12	324
300	5	285	16.2	16	5	292	5.15	12	334

Above datas are for reference only  
\*dimensions not listed in standard  
\*\*stainless material up to diameter 100

Part number built example:

e.g. (1) Select Diameter 20 in steel material      »SF-K040 20.0  
e.g. (2) Select Diameter 55 in stainless material    »SF-K120 55.0



sales@synergixfast.com

www.synergixfast.com

Phone: +65 6 316 2630 | Fax: +65 6 316 2730